



Request for Quotation
PW – 2024-02

SPEED HUMPS, CONSERVATION DR. AND MACLENNAN ST.

Quotations Due by: 2:00 p.m. Tuesday July 30, 2024

Quotations to be presented on forms contained in this document to:

**Harry Niemi, P. Eng.
Director of Public Works
519-856-9596 Ext. 109
roads@get.on.ca**

Both Emailed and hard copy forms will be accepted.

Township of Guelph/Eramosa
8348 Wellington Road 124
P.O. Box 700
Rockwood, ON N0B 2K0

**TOWNSHIP OF GUELPH/ERAMOSIA
REQUEST FOR QUOTATION
PW – 2024 – 02**

EMAILED or SEALED QUOTATIONS will be received at the Township of Guelph/Eramosa Municipal Office until 2:00 p.m. local time on

Tuesday July 30, 2024

Low quote may be awarded by Director of Public Works provided it is within budgeted amount. The lowest or any tender will not necessarily be accepted, however award of work to contractor other than that providing the low quote for any reason shall be subject to Township of Guelph/Eramosa Council approval. A purchase order will be issued to the successful bidder the day following acceptance of quotations unless low quote is not accepted.

The contractor shall provide all the information requested on the attached sheets. Submit sheets 1 through 9.

We (the Contractor) promise to commence work on _____
(to be completed by the contractor) and to diligently perform the work continuously without undue delay with due consideration for the limitations on working in the park as noted above and further promise to complete all work by Friday October 4, 2024.

Township of Guelph/Eramosa
Harry Niemi, P.Eng.
Director of Public Works
8348 Wellington Road 124
PO Box 700
Rockwood ON N0B 2K0
519-856-9596 Ext. 109
Fax - 519-856-2240
roads@get.on.ca

**TOWNSHIP OF GUELPH/ERAMOSIA
REQUEST FOR QUOTATION
PW – 2024 – 02**

**TOWNSHIP OF GUELPH/ERAMOSIA
QUOTATION FOR SPEED HUMPS, CONSERVATION DR. AND MACLENNAN ST.
Quotation NO. PW-2024-02**

The Contractor has carefully examined the conditions and specifications attached and referred to in this contract, and has carefully examined the site and work location and understands and accepts the said conditions and specifications, and for the prices set forth in this quotation, hereby offers to furnish all labour, equipment and materials, except as otherwise specified in the contract, to complete the work in strict accordance with said conditions and specifications.

It is agreed that the quantities are estimated only and may be increased or decreased by the municipality without alteration of the price. However, such increases or decreases shall not exceed 20%.

It is also agreed that, upon acceptance in writing by the municipality this form becomes the “Agreement for the Performance of Work” between the Contractor and the municipality.

This offer shall be irrevocable for a period of thirty (30) calendar days following the date of opening.

I/We (the Contractor) promise to perform the work without undue delay.

Name of Individual or Firm, here after referred to as the “Contractor”:

Address: _____

Phone # / Email Address _____

Signature of Person Signing for Firm: _____

Date: _____

Office of Person Signing for Firm: _____

Witness or Firm Seal: _____

**TOWNSHIP OF GUELPH/ERAMOSIA
REQUEST FOR QUOTATION
PW – 2024 – 02**

QUOTATION PROCEDURES

1. All inquiries concerning the quotation, prior to closing, shall be directed to:

Harry Niemi, P.Eng., Director of Public Works
Township of Guelph/Eramosa
8348 Wellington Road 124
PO Box 700
Rockwood, ON N0B 2K0
519-856-9596 Ext. 109

2. Acceptance notification will be by telephone and written or email form of notice to the address or email of the Contractor used on the tender bid forms. The date of acceptance shall be deemed to be the date of receipt of the Acceptance Notice by the Contractor.

3. A quotation may be voided by superseding it with a later tender or letter of withdrawal, prior to the closing date and time.

BASIS OF REJECTION OF QUOTATION

Quotations not conforming to the following requirements will be disqualified:

1. Quotation must be legible, in ink, by typewriter or by printer.
2. Quotation must be in possession of the municipality by the closing date and time.
3. Quotation must be on the municipal tender bid form provided.
4. All items must be bid.
5. Quotation must not be restricted or modified in any way.

Should the low quotation be rejected for any of the reasons identified, the Director of Public Works may issue a Purchase Order to the next low bid without approval of Council.

BASIS OF PAYMENT

Payment at the Contract price shall be compensation in full for performing the work specified in the quotation item and for the supply of all labour, equipment and materials, (except as otherwise provided in the tender), necessary to complete the work to the satisfaction of the municipality.

COMPLETION DATE

Contractor shall complete the work by:

If the time limit above is not sufficient to permit completion by the Contractor working a normal number of hours, the Contractor shall make changes to permit work to be completed by the above date. Additional costs incurred shall be deemed included in the tender price for the work.

**TOWNSHIP OF GUELPH/ERAMOSIA
 REQUEST FOR QUOTATION
 PW – 2024 – 02**

TOWNSHIP OF GUELPH/ERAMOSIA

**Speed Humps, Conservation Dr. and MacLennan St.
 TENDER BID FORM
 QUOTE NO. PW-2024-02**

I/We understand that this offer, together with a written acceptance thereof by the Township, shall constitute a legal and binding contract between us for the works described in accordance with the attached Description of Works and associated specifications.

Contractor: _____

SCHEDULE OF UNIT PRICES/SUMMARY

ITEM	ITEM DESCRIPTION	Quantity	Unit	Unit Price	TOTAL
1	Supply and Install Speed Humps Complete with Signage and Pavement Markings				
	a) Conservation Drive	3	Ea.	\$	\$
	b) MacLennan Street	3	Ea.	\$	\$
	SUB-TOTAL Bid Price/Estimated Contract Price				\$
	HST (@ 13%)				\$
	TOTAL Bid Price/Estimated Contract Price				\$

All amounts are in Canadian dollars.

The estimated quantities set out in this Schedule are only approximate and the actual measured and approved quantities may vary from such estimated quantities.

The lump sum amounts, and unit prices set out in this Schedule shall apply to the Contract and are inclusive of all costs and expenses required to perform and complete the Work including, without limitation, all applicable federal and provincial sales taxes, excise taxes and other taxes, insurance, permits, customs, duties and transportation, except for the HST.

**TOWNSHIP OF GUELPH/ERAMOSIA
REQUEST FOR QUOTATION
PW – 2024 – 02**

DESCRIPTION OF WORKS

The following sections outline the scope of work for each of the line items included in the Tender Bid Form above. Payment under the items is inclusive of all costs associated with completing the work including but not limited to, mobilization, traffic control and any other requirements described within this document.

Schedule A-Speed Humps, Conservation Dr. and MacLennan St.

PERMANENT SPEED HUMPS

The unit price bid for this item shall include the cost for all labour, materials and equipment required to construct the speed humps on Conservation Drive and MacLennan Street and to include signage and pavement markings.

Basis of Payment

Payment is per each unit of completed permanent speed cushion with existing asphalt milled to 0.050 m below grade and finished speed cushion height of 0.08 m above grade (0.130 m total height), and shall include full payment for the supply of all labour, equipment and materials required for:

- The removal or grinding, and disposal of, hot mix asphalt pavement,
- Application of tack coat,
- Supply, hand placement, forming, grading, and compaction of hot mix asphalt speed cushions comprised of HL-3 asphalt PGAC 58-28,
- Placement of durable markings as per the provided Standard Drawing, and
- Supply and install Wa-74 and Wa-74T signage.

All asphalt speed cushions shall be completed within twenty-four (24) hours of grinding.

At roadway locations encountering discontinuities, applicable warning signs are to be placed, and edges are to be identified.

All vertical discontinuities are to be ramped with a smooth and adequate transition, until such time the final course is placed. The Contractor is to select a method to allow a smooth transition from the repaired area to the adjacent existing finished asphalt. No granular material including asphalt grindings are to be used for ramping.

Immediately prior to asphalt placement, all contact surfaces shall have tack coat applied in accordance with OPSS 310, OPSS 1150, OPSS 1103. Tack coat will not be applied when pavement temperature is less than 5° C or if rain or frost is likely to occur before the emulsion cures. Tack coat will be placed far enough in advance of paving to ensure adequate curing.

**TOWNSHIP OF GUELPH/ERAMOSIA
REQUEST FOR QUOTATION
PW – 2024 – 02**

PAYMENT TERMS

Payment will be made in response to the Contractor's invoice. This payment will be made when all work has been completed to the satisfaction of the Director of Public Works. Payment to the Contractor shall be verified from measurements taken and recorded by the Director of Public Works or designate.

The Township shall retain a Holdback payment of ten percent (10%) of the total invoiced amount. Release of the Holdback shall be made after forty-five (45) calendar days from the date of completion of the work as established by the Completion Certificate, but subject to the provisions of RSO 1990, c.C.30, as amended, and the submission by the Contractor of the following documents:

1. A release shall be provided by the Contractor in a form satisfactory to the Director of Public Works, releasing the Township from any claims relating to the Contract, qualified by stated exceptions, where appropriate.
2. A statutory declaration shall be provided in a form satisfactory to the Director of Public Works, that all liabilities incurred by the Contractor and the Contractor's Subcontractors in carrying out the work have been discharged, qualified by stated exceptions where appropriate, and a satisfactory Certificate of Clearance from the Workplace Safety and Insurance Board.

CONTRACTORS TO INVESTIGATE

Contractors must satisfy themselves by personal examination of the Township Road system in order to assess the methods and general requirements of the work.

GOODS AND SERVICES TAX

Unit and/or lump sum prices shall not include the Harmonized Sales Tax.

CONTRACTORS EXPERIENCE, ABILITY, CAPITAL AND PLANT

The Township expects that all Contractors will be able to furnish satisfactory evidence that they have the ability, experience, capital and plant to enable them to prosecute and complete the contract successfully. Contractors must be authorized to do business in the Dominion of Canada and the Province of Ontario.

**TOWNSHIP OF GUELPH/ERAMOSIA
REQUEST FOR QUOTATION
PW – 2024 – 02**

To aid the Township in determining the responsibility of each Contractor, the following statements are required and included as part of the Form of Tender:

Statement “A”: Stating the Contractor’s experience in similar work that was successfully completed.

Statement “B”: Giving the name and address of each proposed Subcontractor used in making up the tender and shall state the portion of the work allotted to each. Only one Subcontractor shall be named for each part of the work to be sublet.

Statement “C”: List of Suppliers.

STATEMENT “A” – Contractor’s experience for references

STATEMENT “B” – List of Subcontractors

STATEMENT “C” – List of Suppliers

**TOWNSHIP OF GUELPH/ERAMOSIA
REQUEST FOR QUOTATION
PW – 2024 – 02**

I/We agree that this offer shall remain open for acceptance until the formal Contract is executed by the successful Contractor for the said work or until forty-five (45) calendar days after the said opening, whichever event first occurs; and that the Township may, at any time within that period and without notice, accept this Tender whether any other Tender has previously been accepted or not.

I/We agree that the awarding of the Contract, based on this Tender, by the council of the Township of Guelph Eramosa shall constitute acceptance.

I/We hereby agree that notification of acceptance of this Tender shall be in writing and may be sent by prepaid post. If sent by prepaid post, acceptance shall be deemed to have been made on the date of the mailing of notification.

Name of Signing Authority for Contractor:

(Please Print) _____

Position: _____

Signature: _____

Witness: _____

Place Seal of Contractor Here

**TOWNSHIP OF GUELPH/ERAMOSA
REQUEST FOR QUOTATION
PW – 2024 – 02**

GENERAL TERMS AND CONDITIONS

REFERENCES

Wherever in this Contract reference is made to the General Conditions, it shall be interpreted as meaning the Ontario Provincial Standards for Roads and Public Works – General Conditions of Contract, dated November 2019 (OPSS.MUNI 100). All requirements of these General Conditions shall apply unless stated otherwise herein. The Contractor is responsible for obtaining a copy of the General Conditions as they are not reproduced herein.

PRICING REQUIREMENTS

Prices shall be in Canadian Funds, quoted separately for each item stipulated, F.O.B. to the point specified therein.

All prices tendered shall include applicable taxes, customs duty, excise tax, freight, insurance and all other charges of every kind attributable to the work. The prices shall not include Harmonized Sales Tax.

LOADING OF MOTOR VEHICLES

Where a vehicle is hauling material for use in the work under this contract, in whole or in part on a public highway and where motor vehicle registration is required for such vehicles, the Contractor shall not cause or permit such a vehicle to be loaded beyond the legal limit as specified in the Highway Traffic Act, whether such vehicle is registered in the name of the Contractor or otherwise.

DAMAGE BY VEHICLES AND OTHER EQUIPMENT

If at any time, in the opinion of the Director of Public Works or designate, damage is being done or is likely to be done to any highway or any improvement thereon, other than such portions as are part of the work by the Contractor's vehicles or other equipment whether licensed or unlicensed, the Contractor shall, on the direction of the Director of Public Works, and at the Contractor's own expense, make changes in or substitutions for such vehicles or other equipment; or shall alter loadings or shall in some other manner remove the cause of such damage to the satisfaction of the Director of Public Works.

**TOWNSHIP OF GUELPH/ERAMOSIA
REQUEST FOR QUOTATION
PW – 2024 – 02**

SPILLS REPORTING

Spills or discharge of pollutants or contaminants under the control of the Contractor and spills or discharges of pollutants or contaminants that are a result of the Contractor's operations that cause or are likely to cause adverse effects shall for with be reported to the Township. Such spills or discharges and their adverse side effects shall be as defined in the Environmental Protection Act R.S.O. 1990.

INSURANCE REQUIREMENTS

The Contractor covenants and agrees to indemnify and save harmless the Township from and against all claims for loss, costs, damages, and/or compensation and legal expenses the Township may incur as the direct or indirect result of the work operation described herein being carried out by the Contractor. The Contractor shall secure and maintain at their expense during the duration of this contract, general comprehensive liability insurance in an amount not less than five million dollars (\$ 5,000,000.00) per incident, naming the Township of Guelph/Eramosa as an additional named insured and containing a cross-liability endorsement.

The Contractor shall deliver, within ten (10) calendar days of receiving the acceptance notice, a certified copy of the Firm's Public Liability and Property Damage Insurance Policy for the work, in the form of a certificate from their insurance company.

The Contractor shall also deliver, within ten (10) calendar days of receiving the acceptance notice, proof of Workplace Safety and Insurance Board coverage.

Failure to provide either proof shall result in the cancellation of the contract and forfeiture of the tender deposit (if applicable).

**TOWNSHIP OF GUELPH/ERAMOSIA
REQUEST FOR QUOTATION
PW – 2024 – 02**

DEFAULT BY CONTRACTOR

If the Contractor commits any act of bankruptcy; or if a receiver is appointed on account of its insolvency or in respect of any of its property; or if the Contractor makes a general assignment for the benefit of its creditors; then, in any such case, the Township may terminate the contract without notice.

If the Contractor fails to comply with any request, instruction, or order of the Township; or fails to pay its accounts; or fails to comply with or persistently disregard statutes, regulations, by-laws, or directives of relevant authorities relating to the work; or fails to execute the work with the required skill and diligence; or assigns/sublets the contract or any portion thereof without the Township's written consent; or refuses to correct defective work; or is otherwise in default carrying out its part of any of the terms, conditions and obligations of the contract, then, in any such case the Township may terminate the contract upon expiration of ten (10) days from the date of written notice to the Contractor.

Any termination of the contract by the Township, as aforementioned, shall be without prejudice to any other rights or remedies the Township may have.

If the Township terminates the contract, it is entitled to:

1. Take possession of all the work in progress and finish the work by whatever means deemed appropriate under the circumstances.
2. Withhold any payment to the Contractor until its liability to the Township is ascertained.
3. Recover from the Contractor any loss, damage, and/or expense incurred by the Township by reason of the Contractor's default, which may be deducted from any monies due or becoming due to the Contractor, and any other balance to be paid by the Contractor to the Township.

**TOWNSHIP OF GUELPH/ERAMOSA
REQUEST FOR QUOTATION
PW – 2024 – 02**

CONTRACTOR’S DISCHARGE OF LIABILITIES

The Contractor shall discharge and cause each Subcontractor to discharge all liabilities incurred for labour, materials, or services used or reasonably required for use in the performance of this contract on the date upon which each becomes due. The Contractor shall furnish the Township with a Statutory Declaration providing confirmation that their liabilities and those of the Subcontractors, as aforementioned, have been discharged and this shall include a certificate or certificates from the Workplace Safety and Insurance Board that they have complied with the requirements of the Workplace Safety and Insurance Board and are in good standing in the books of the board.

No payment to which the Contractor is otherwise entitled under this contract shall be due and payable to them so long as they or any Subcontractors are in default under this section, and upon such default occurring, the Township may, in respect of claims submitted by creditors having a contractual relationship with the Contractor, after notice in writing to the Contractor and their surety, withhold payment of the whole or any part of any such liability of the Contractor. Interest will not be paid on any such funds withheld.

CONTRACT TIME AND LIQUIDATED DAMAGES

It is agreed by the parties to this contract that in the event that all the work called for under the contract is not completed by the date specified, or as extended by the Director of Public Works, a loss or damage will be sustained by the Township. Since it is and will be impractical and extremely difficult to ascertain and determine the actual loss or damage which the Township will suffer in the event of and by reason of such delay, the parties hereto agree that the Contractor will pay to the Township the sum of five hundred dollars (\$500.00) as liquidated damages for each and every calendar day delay in achieving completion of the work beyond the date prescribed. It is agreed that this amount is an estimate of the actual loss or damage to the Township, which will accrue during the period in excess of the prescribed date for completion.

The Township may deduct any amount under this paragraph from any monies that may be due or payable to the Contractor on any account whatsoever. The liquidated damages payable under this paragraph are in addition to and without prejudice to any other remedy, action or other alternative that may be available to the Township.

COMPLIANCE WITH THE OCCUPATIONAL HEALTH AND SAFETY ACT

The Contractor shall execute the terms of the contract in strict compliance with the requirements of the Occupational Health and Safety Act, RSO 1990, c.0.1 (the Act) and Ontario Regulation 213/91 (Construction Projects) and any other regulations under the Act (the Regulations) which may affect the performance of the work, as the Contractor or Employer, as the case may be.

**TOWNSHIP OF GUELPH/ERAMOSA
REQUEST FOR QUOTATION
PW – 2024 – 02**

Worker safety is given priority in planning, pricing and performing the work. Its officers and supervisory employees must have a working knowledge of the duties of a Contractor and Employer under the Act and the provisions of the Regulations applicable to the work, and a personal commitment to comply with them. Workers employed to carry out the work possess the knowledge, skills, and protective devices required by law or recommended for use by a recognized industry association to allow them to work in safety; Its supervisory employees carry out their duties in a diligent and responsible manner with due consideration for the health and safety of the workers.

All Subcontractors employed by the Contractor to perform part of the work and their employees are properly protected from injury while carrying out their associated duties. The Contractor shall cooperate with representatives of the Township and inspectors appointed to enforce the Act and the Regulations in any investigations of worker health and safety in the performance of the work. The contractor shall identify and save the Township from any additional expense which may be incurred to have the work performed as a result of the Contractor's failure to comply with the requirements of the Act and the Regulations.

PROTECTION OF THE PUBLIC AND TRAFFIC

All traffic control procedures and devices shall conform to the requirements of the following references:

1. The Ministry of Transportation-Traffic Control Manual for Roadway Operations
2. The Ministry of Transportation-Ontario Traffic Manual – Book 7
3. Canadian Government Specification Standard 62-GP-11, as amended, Reflective Materials and Surfaces

The Contractor will be responsible for maintaining one lane of vehicular traffic. Barricades, warning signs, lights, and all necessary detour signs within the limits of the Contract shall be maintained throughout the course of the work, all at the expense of the Contractor and to the satisfaction of the Director of Public Works or designate.

Materials and equipment shall not be stored within 4 m of the travelled portion of the roadway. In addition, the Contractor shall, at their own expense, remove any equipment or material which the Director of Public Works or designate constitutes as a traffic hazard.

**TOWNSHIP OF GUELPH/ERAMOSA
REQUEST FOR QUOTATION
PW – 2024 – 02**

TRAFFIC PROTECTION PLAN AND MEASURES

The Contractor shall prepare detailed procedures for addressing the traffic protection requirements of the Occupational Health and Safety Act and Ontario Regulations for Construction Projects, Ontario Regulation 213/19 as amended by 143/99, 175/99 and 145/00 and they shall be provided to the Contractors' workers, the Township, and the Director of Public Works. The procedures must include protection for the Director of Public Works and all Township personnel involved in surveying or inspection operations of the contract.

The Contractor shall have competent workers trained in the installation and removal procedures of roadside operations, as provided for in the Ontario Traffic Manual Publication – Book 7.

LIABILITY INSURANCE

The successful contractor shall file with the owner a certified copy of an Insurance Policy or an Insurance Certificate acceptable to the owner with a limit of not less than five million dollars (\$5,000,000.00) prior to commencing work.

General liability insurance shall be in the joint names of the Contractor and the Owner with limits of not less than five million dollars (\$5,000,000.00) inclusive per occurrence for bodily injury, death and damage to property including loss of use and thereof, with a property damage deductible of not more than five thousand dollars (\$5,000.00). The form of insurance shall be the Insurance Bureau of Canada Form IBC 2100 dated 01-11 or approved equivalent.

Failure to comply with the aforesaid shall be interpreted as "No Insurance" and will result in the cancellation of any contract agreed upon.

**TOWNSHIP OF GUELPH/ERAMOSA
REQUEST FOR QUOTATION
PW – 2024 – 02**

CONTRACTOR'S LIABILITY

1. Any work performed by the contractor on the lands of the Township shall be solely at their own risk and the Township shall not be liable to the contractor or their employees for any damages or loss sustained by them, including death, or to their property as a result of working or operation there upon.
2. The contractor shall be responsible for any damages or loss sustained by any person, including death, or to their property as a result of working or operating upon the lands of the Township and shall obtain public liability and property damage insurance for their vehicles(s), both to the satisfaction of the Township.
3. The contractor shall be responsible for any damages or loss sustained by any person, including death, or to their property as a result of any failure or neglect on the part of the contractor or their employees to perform any of the acts or obligations required under this contract.
4. The contractor shall indemnify and save the Township harmless for all such damages or loss, claims therefore, costs and expenses which may be incurred by the Township as a result of the award of the contract to the contractor.

WORKPLACE SAFETY AND INSURANCE BOARD

The contractor shall provide the Township with a copy of a Certificate of Clearance indicating the Contractor's good standing with the Workplace Safety and Insurance Board, within ten (10) calendar days of receiving the acceptance notice. The Contractor shall execute the terms of the Contract in strict compliance with local by-laws, the requirements of the Occupational Health and Safety Act, R.S.O. 1990, c.O.1 as amended (the Act), and Ontario Regulation 213/91 as amended, and any other regulations as amended under the Act that may affect the performance of the Work as the 'Constructor' or 'employer', as defined by the Act as the case may be.

**TOWNSHIP OF GUELPH/ERAMOSIA
REQUEST FOR QUOTATION
PW – 2024 – 02**

HARMONIZED SALES TAX

All bidders will indicate the amount of Harmonized Sales Tax to be paid.

REGULATIONS

The contractor shall abide by all Acts, By-Laws and regulations relative to the performance of the work.

COMPLETION

Time shall be of the essence of the agreement.

PAYMENTS

Following completion of the work, the Contractor is to submit a detailed invoice indicating the amount and contract number, to the Township of Guelph/Eramosa for the work performed. Within forty-five (45) days of the date of acceptance of the work a cheque will be released to the contractor.

DIRECTOR OF PUBLIC WORKS OR DESIGNATE

Director of Public Works or Designate shall be interpreted as any such person, partnership or corporation as may be authorized by the Council of the Township of Guelph/Eramosa to act on their behalf in any particular capacity.

ONTARIO PROVINCIAL STANDARD SPECIFICATIONS

The Ontario Provincial Standards shall apply to this project as determined by the Director of Public Works.

Drawings

Drawing No.	Drawing Title
001	Location Plan Conservation Drive
002	Location Plan MacLennan Street
003	Figure 4.6 - Speed Hump
004	Speed Cushon Site Detail

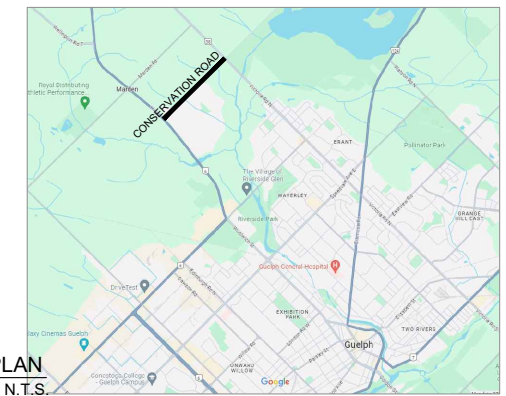
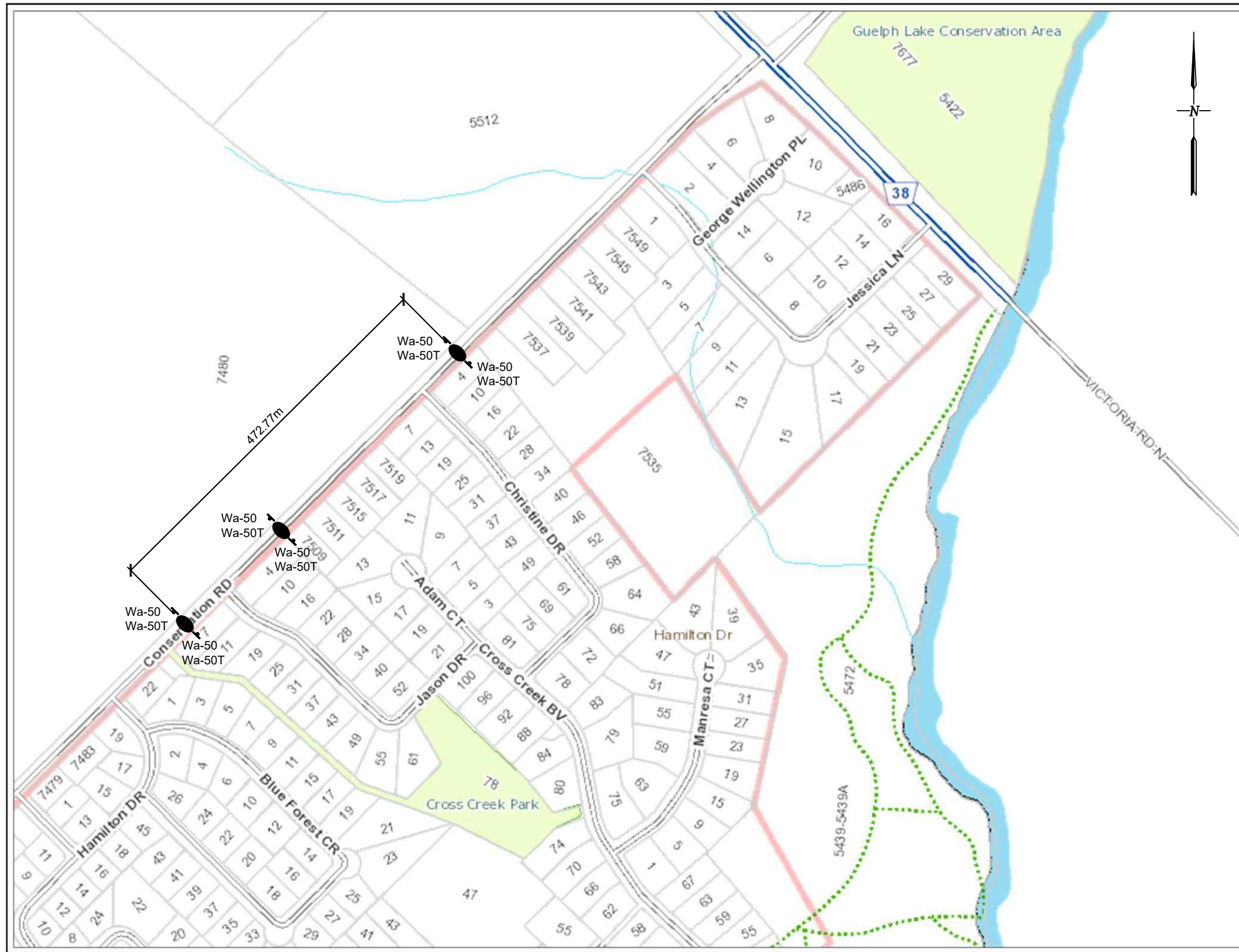

KEY PLAN
SCALE: N.T.S.

- Notes
1. This drawing is the exclusive property of R. J. Burnside & Associates Limited. The reproduction of any part without prior written consent of this office is strictly prohibited.
 2. The contractor shall verify all dimensions, levels, and datums on site and report any discrepancies or omissions to this office prior to construction.
 3. This drawing is to be read and understood in conjunction with all other plans and documents applicable to this project.

NOT FOR CONSTRUCTION

No.	Issue / Revision	Date	Auth.



R.J. Burnside & Associates Limited
15 Townline
Orangeville, Ontario, L9W 3R4
telephone 1-800-265-9662
web www.rjburnside.com

Client
TOWNSHIP OF GUELPH/ERAMOSA
8348 WELLINGTON ROAD 124 P.O. BOX 700
ROCKWOOD, ONTARIO
NOB 2K0

Drawing Title
GET 2024 SPEED HUMP
SPEED CUSHION LOCATION PLAN -
CONSERVATION ROAD

Drawn CADD	Checked GC	Date 24/07/05	Drawing No. 001
Scale NTS	Project No. 300058886		

- DENOTES SPEED CUSHION
- Wa-50
- Wa-50T

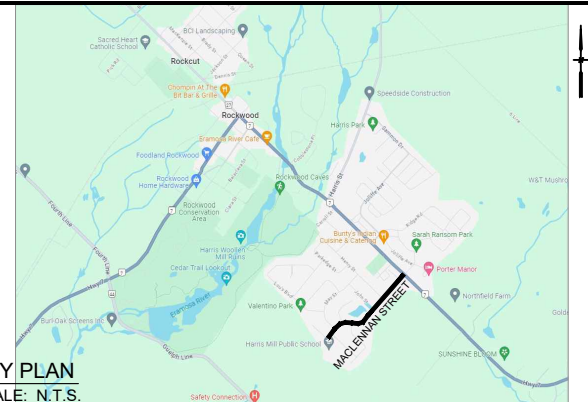
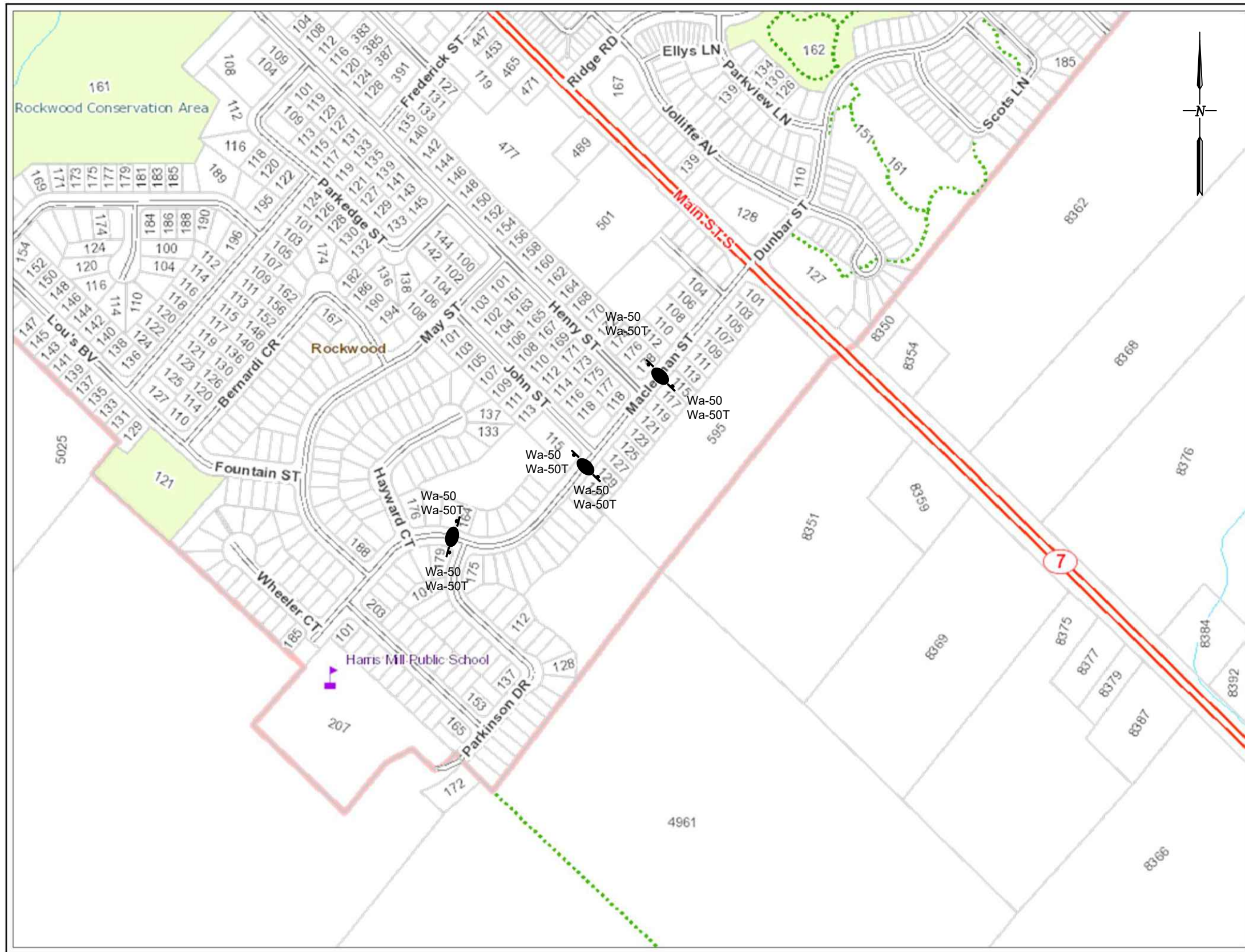

KEY PLAN
SCALE: N.T.S.

- Notes
1. This drawing is the exclusive property of R. J. Burnside & Associates Limited. The reproduction of any part without prior written consent of this office is strictly prohibited.
 2. The contractor shall verify all dimensions, levels, and datums on site and report any discrepancies or omissions to this office prior to construction.
 3. This drawing is to be read and understood in conjunction with all other plans and documents applicable to this project.

NOT FOR CONSTRUCTION

No.	Issue / Revision	Date	Auth.



R.J. Burnside & Associates Limited
 15 Townline
 Orangeville, Ontario, L9W 3R4
 telephone 1-800-265-9662
 web www.rjburnside.com

Client
TOWNSHIP OF GUELPH/ERAMOSA
 8348 WELLINGTON ROAD 124 P.O. BOX 700
 ROCKWOOD, ONTARIO
 NOB 2K0

Drawing Title
GET 2024 SPEED HUMP

SPEED CUSHION LOCATION PLAN -
 MACLENNAN STREET

Drawn CADD	Checked GC	Date 24/07/05	Drawing No. 002
Scale NTS	Project No. 300058886		

● DENOTES SPEED CUSHION Wa-50 Wa-50T

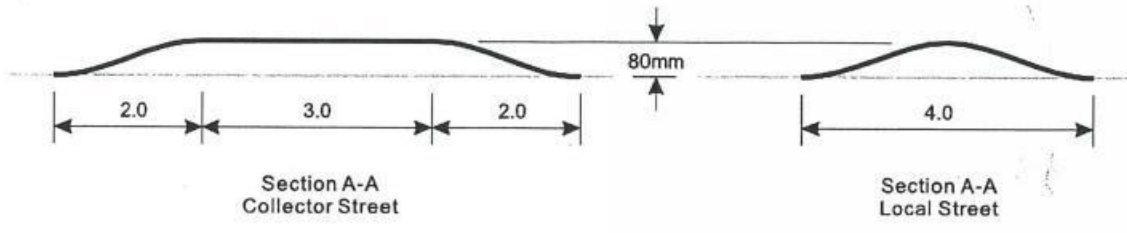
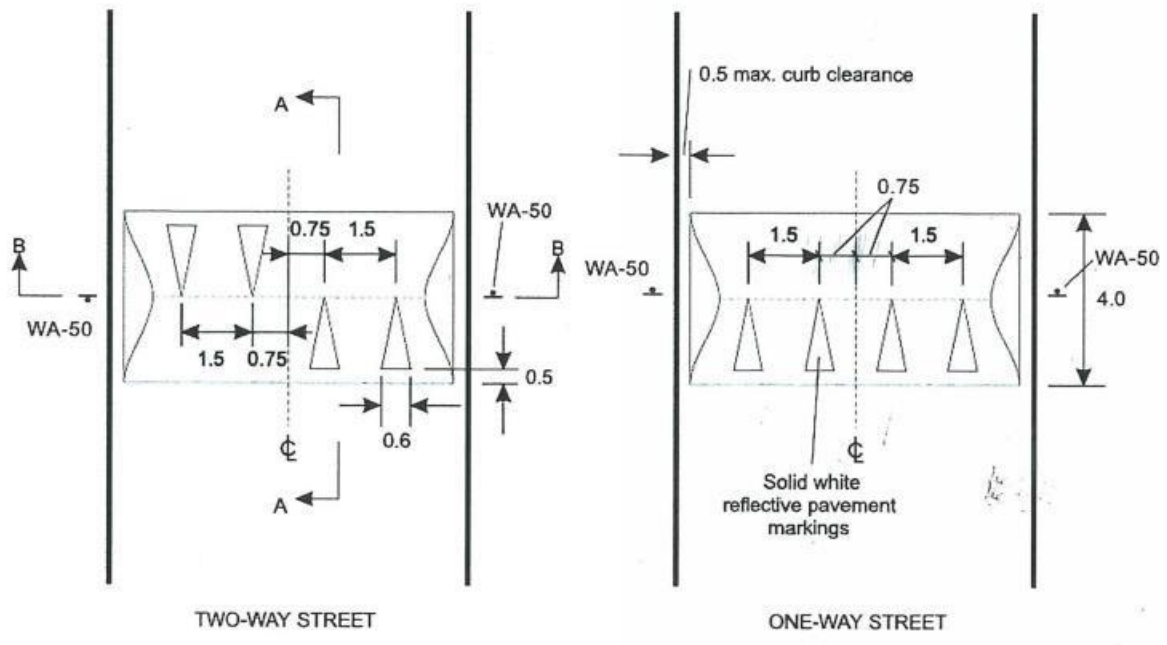

Sinusoidal Speed Hump Development

Distance (m)	0.000	0.125	0.250	0.375	0.500	0.625	0.750	0.875	1.000	1.125	1.250	1.375	1.500	1.625	1.750	1.875	2.000
Finished Height (mm)	0	1	3	7	12	18	25	32	40	48	55	62	68	73	77	79	80

Sign Descriptions:
 WA-50 Speed Hump

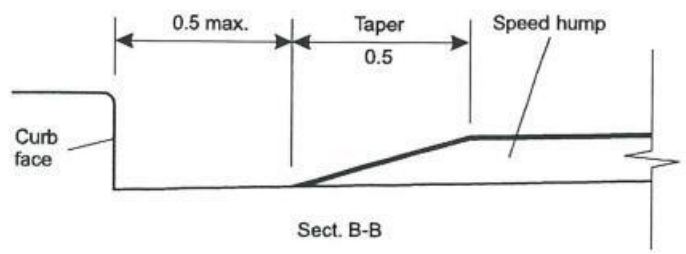

All dimensions are in metres unless otherwise noted.

NOT TO SCALE

FIGURE 4.6 – SPEED HUMP

SPEED CUSHION INSTALLATION - CONSERVATION DRIVE

REFER TO FIGURE 4.6

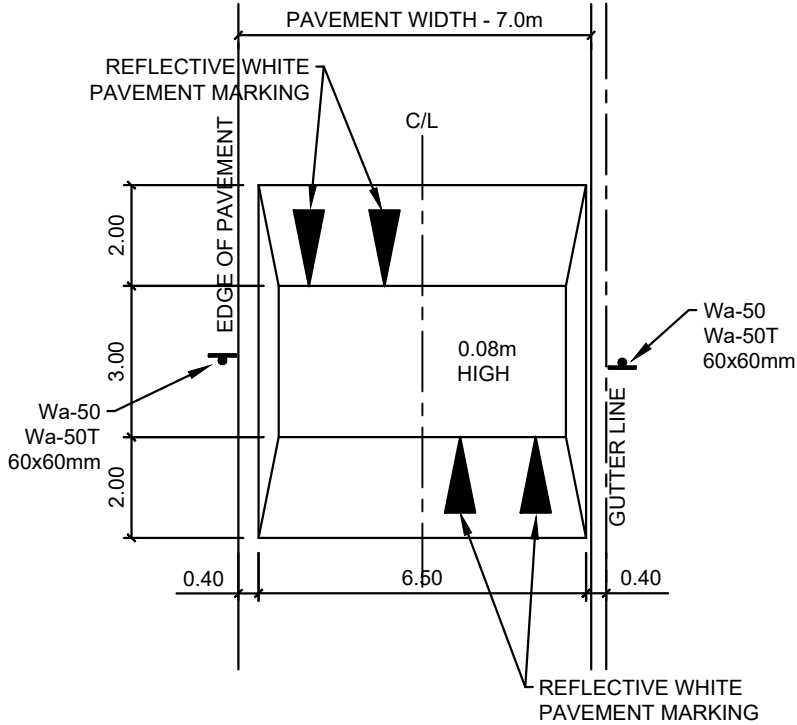

SPEED CUSHION INSTALLATION - MACLENNAN STREET

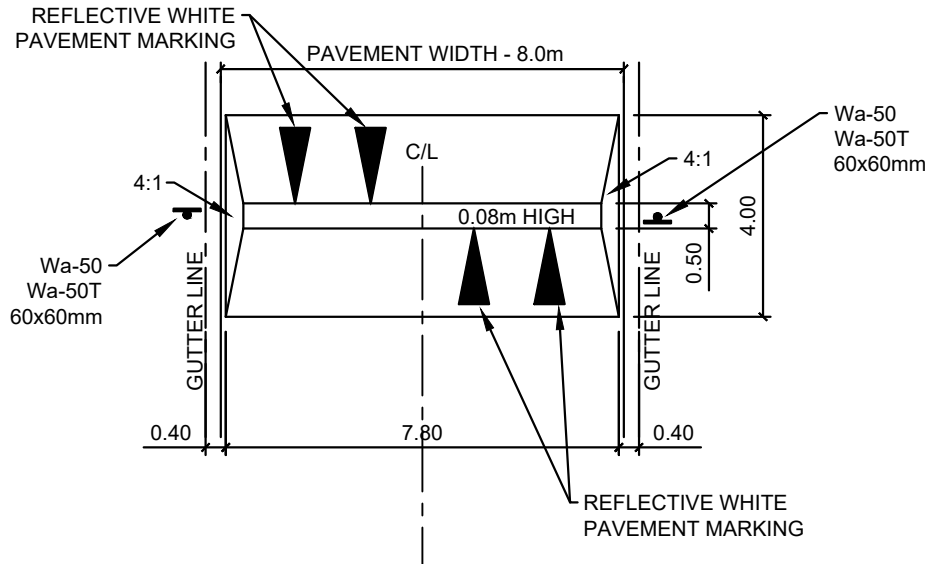

15 Townline, Orangeville, Ontario, L9W 3R4
telephone 1-800-265-9662

Client
TOWNSHIP OF GUELPH/ERAMOSA

8348 WELLINGTON ROAD 124 P.O. BOX 700
ROCKWOOD, ONTARIO
NOB 2K0

Drawing Title

GET 2024 SPEED HUMP

SPEED CUSHION SITE DETAIL

Drawn	Checked	Date	Drawing No.
CADD	GC	24/07/11	
Scale	Project No.		004
1:150	300058886		